



Ensuring compliance through technology with the most innovative corrugated displays in the market



-   
Canada  
Head Office
-   
U.S.A
-   
France
-   
Spain
-   
Portugal
-   
Belgium
-   
Germany
-   
Italy
-   
Switzerland
-   
Turkey
-   
United Kingdom
-   
Mexico

# **Poptech's Point of Purchase Technology.**

## **A revolutionary new approach in the display industry.**



- **Assembly time** - *The fastest in the business!*
- **Guaranteed set-ups** - *An industry first!*
- **Reduced packouts** - *Big savings on shipping & warehousing!*

***Designed and proven to significantly increase assembly rate compliance, product sell through and R.O.I. on merchandising monies spent.***

### **Testimonials:**

*"Awesome product. Space and freight savings are significant. Excellent service. Easiest displays in the industry to assemble and use."*

**Rob Stahler - Sales & Marketing - Stephen Gould Corp**

*"I think Poptech's corrugate designs are durable, customizable and simple to setup. The 'pop-up' design helps ensure that retail staffers choose to setup our promotion because they know it will be easy."*

**Blaine Schwingenschlegel - Manager of Business Development - Sony BMG Music Canada**

*"Poptech not only develops great innovative displays but is always focused on understanding our target market. They strive to keep our desired budget requirements while ensuring that our displays generate incremental sales."*

**Gilles Thibeault - Retail Marketing Manager - Levi Strauss & Co. (Canada) Inc.**

'Pop-Up' Brochure Holders. 'Swing and Lug-in' Pocket, small footprint, big bang for your buck. Endless potential.

**Client:** SkyHawke

**Specifications:**

Patented Pop-Up Easel  
Pre-Attached Brochure Holder

**Options:**

Various shapes & sizes  
Multiple pocket configurations for brochures, recipe cards, etc.  
Existing in house dies

**24" Pop-Up Counter Top Brochure Holder**



Patented Pop-Up Easel



Pre-Attached Brochure Pocket

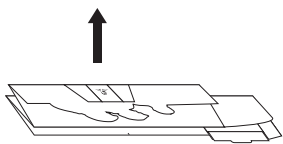

1. Lift up.

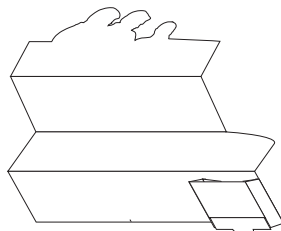

2. Display pops into place.

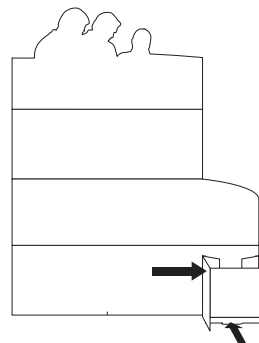

3. Slide brochure pocket open, and lock bottom tab into place.

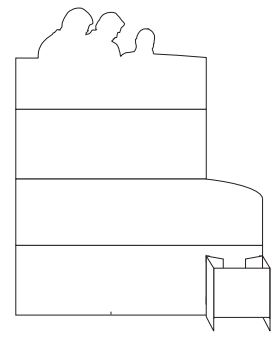

4. Assembly complete!

This counter unit features a stepped design which showcases the product as well as an integrated brochure pocket.

**Client:** Abbott Laboratories

**Specifications:**

Patented Pop-Up Easel  
Integrated Brochure Pocket

# 16" Pop-Up Two Step Counter Unit



Patented Pop-Up Easel



Integrated Brochure Pocket

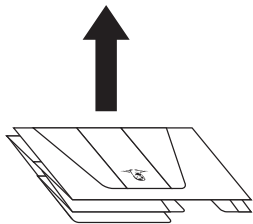

1. Lift up.

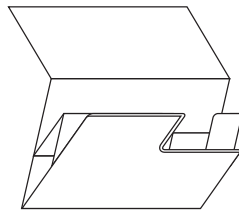

2. Display pops into place.

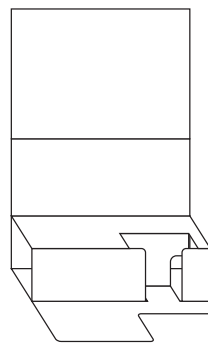

3. Assembly complete.

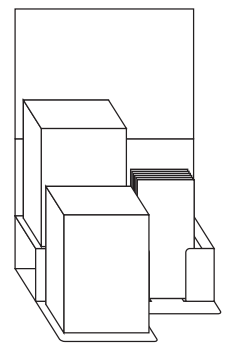

4. Place 2 Freestyle units on steps and brochures in pocket.

## Additional Counter Unit Designs



You can't go wrong with a 'Pop-up' Standee! Quick & easy to assemble. \*Reduced pack out size by as much as 1/3 of a conventional standee significantly decreasing shipping and warehousing costs. With the many relief cut options and stunning graphic concepts this is going to be turning heads!

**Client:** Pepsi

**Specifications:**

Patented Pop-Up Easel

**Options:**

- Small, medium & large formats
- Rectangle shapes or relief cut options
- Lug-ons for 3D effects
- Existing in house dies

**\*Standard UPS - 3 day service**

Conventional carton size:  
36" X 36" X 2" Weight: 5lbs.  
Chicago → New York: **\$36.19**

Poptech carton size:  
36" X 19" X 2" Weight: 5lbs.  
Chicago → New York: **\$7.58**

**72" Pop-Up Standee**



Patented Pop-Up Easel

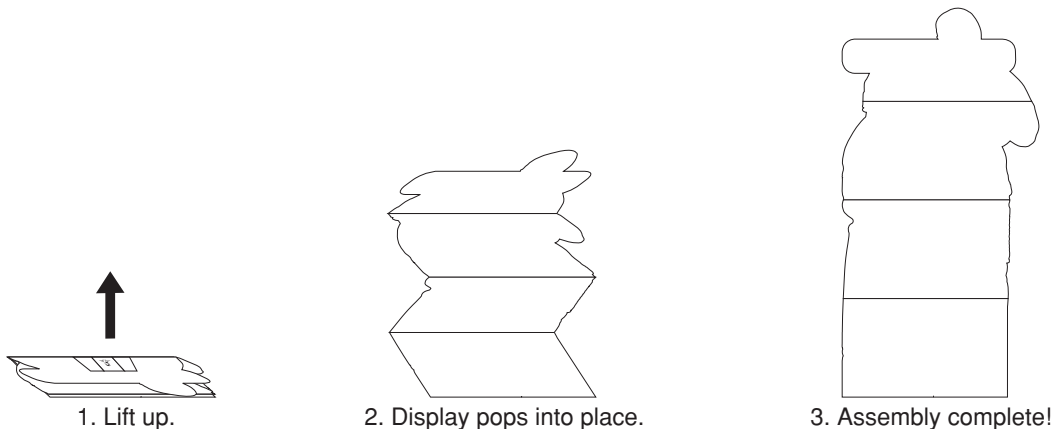

Taking our patented pop-up easel to the next level. This display features a large side flap that folds back creating a two sided standee, which adds a whole new dimension to this display.

**Client:** Nintendo

**Specifications:**

Patented Pop-Up Easel

**Options:**

Small, medium & large formats  
1-3 panel layouts

## 67" Pop-Up Standee



Patented Pop-Up Easel

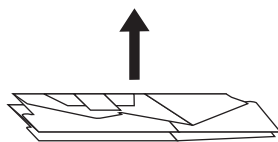

1. Lift up.

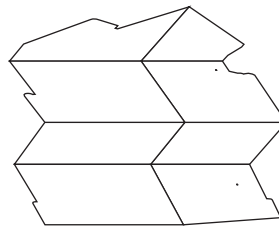

2. Display pops into place.

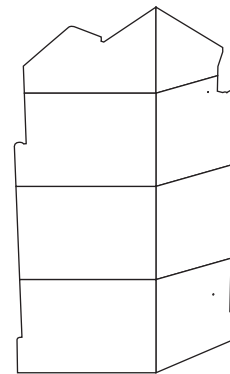

3. Assembly complete!

## Additional Large Pop-Up Standee Designs





*What a concept! The client receives this fully assembled and packed out display, simply lifts carton lid, flips up pre-affixed header and loads product into tray. Upon delivery, retailer opens lid, lifts unit up, base pops up and header swings into place. All this with the Poptech guarantee. Like we said... What a concept!*

**Client:** Wrigley's

**Specifications:**

- Patented Pop-Up Base
- Pre-Affixed Top Loading Friendly Tray
- Pre-Attached Header

**Options:**

- Small, medium & large bases
- Multiple tray dimensions
- Dumpbin capabilities
- Existing in-house dies

**48" Top Loader  
Pop-Up Base**

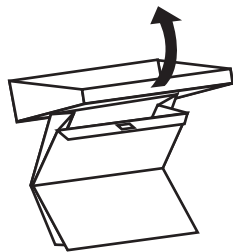

1. Lift display out of box while tilting tray back.

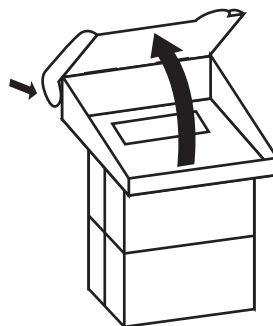

2. Swing and lug Header into place.

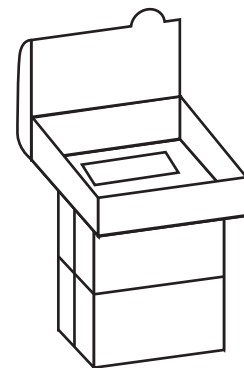

3. Assembly complete!

1,2,3 BAM! Out of the shipper and fully loaded in under 10 seconds! Custom sizes for a wide variety of products.

**Client:** Heinz

**Specifications:**

Patented Pop-Up Base  
Ships Pre-Packed And Fully Assembled

## Pop-Up Lean Back

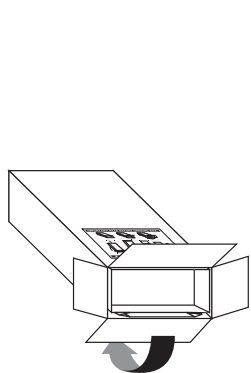
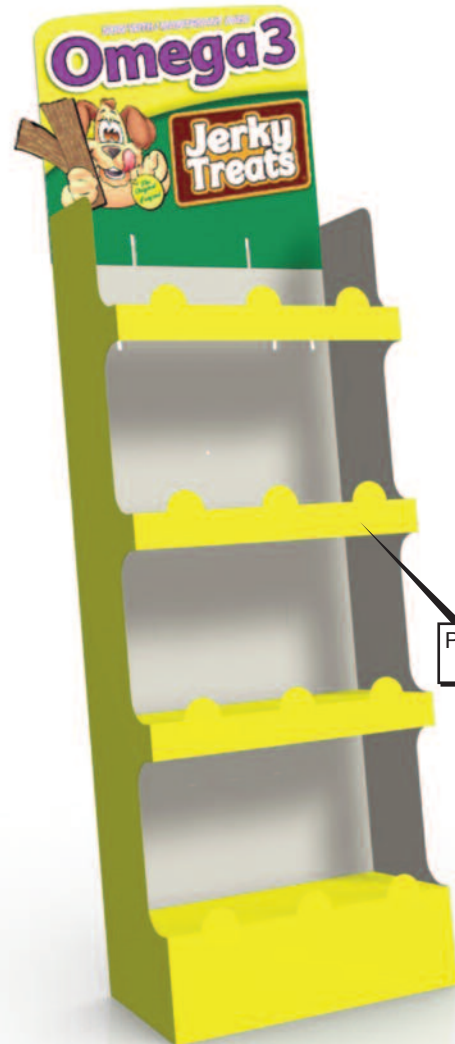

1. Open box.

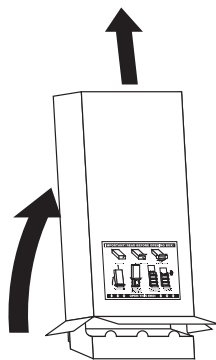

2. Tilt box upwards and slowly slide box up off of display.

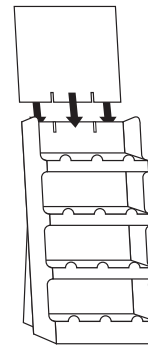

3. Attach header card to display by sliding the outer two tabs behind display and the center tab in front of the display.

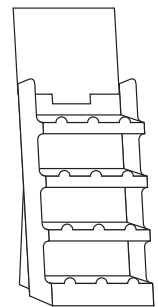

4. Assembly complete.

1,2,3 Bam! Where have we heard that one before? As with most of our patented or patent pending product line-up, this baby delivers! And... did we already say **BIG SAVINGS ON SHIPPING?**

**Client:** Wrigley's

**Specifications:**

Patent Pending Stepped Tray

**Options:**

Various shapes & sizes  
Multiple tray configurations and custom combinations  
Existing in house dies

**48" 3 Step**

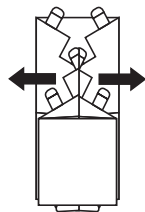

1. Spread sides apart until they are straight.

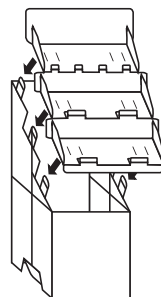

2. Place tray on base by sliding base tabs through slots closest to edge of tray.

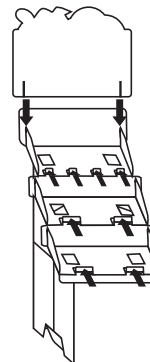

3. Slide header card between sides of top tray and in front of back panel.

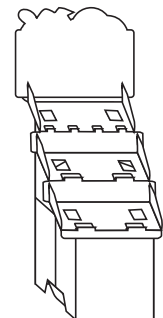

4. Assembly complete!

*Reduced shipping cost! Reduced foot print!  
 Assembly so quick and easy it should be  
 outlawed! Holds an impressive amount of  
 product! Multiple tray and / or pegless tray  
 configurations. Two sided and one sided  
 options! Need we say more?*

**Client:** Wrigley's

**Specifications:**

*Patented Pop-Up Base  
 Patented Easy Lug-In Trays  
 24 pt. Card Stock Header*

**Options:**

*Small, medium & large base formats  
 Multiple pegable tray dimensions  
 Various header cards  
 Existing in house dies*

**61" Pop-Up A-Frame  
 Merchandiser**

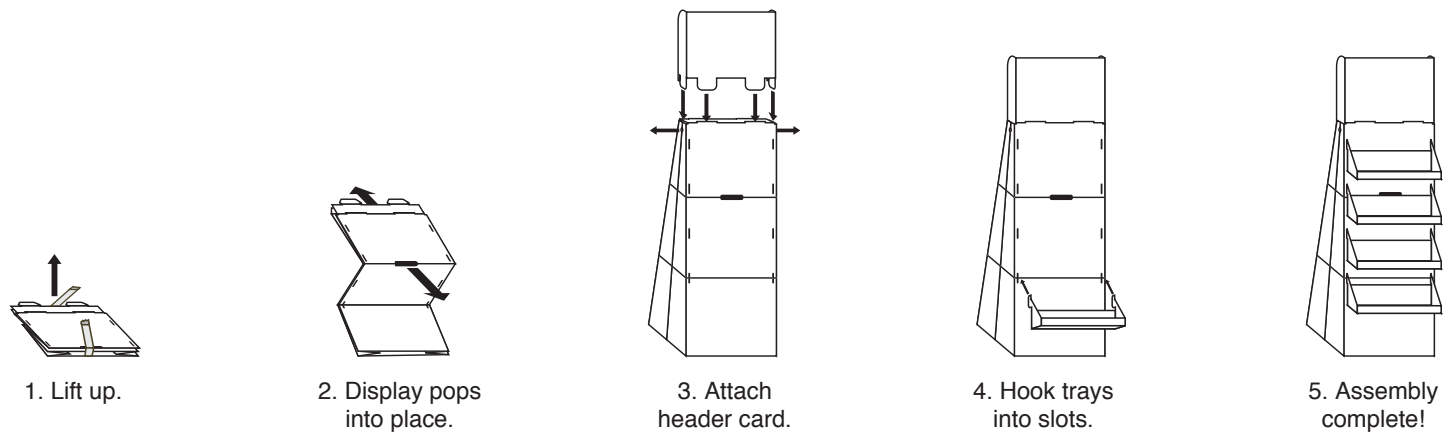

### Generic A-Frame Display

With quick time assembly, reduced packouts & guaranteed set-ups, this pop-up merchandiser is a giant leap forward for the point of purchase display industry. Featuring our patented 'easy lug-in' trays and patented pop-up base, we've transformed an old idea into one of the most exciting displays on the market! If that wasn't impressive enough, check out the low price tag & take advantage of existing dies.

### Display dimensions:

Height: 47" (61" including header card)

Width: 19"

Depth: 17"

### Single tray dimensions:

17 3/4" wide X (your choice of either)

Large: 7" deep, or Small: 5" deep

Media (Qty's per single tray)	DVD	VHS	CD
Small Tray No Filler	24 pcs.	16 pcs.	33 pcs.
Small Tray Filler	18 pcs.	12 pcs.	24 pcs.
Large Tray No Filler	33 pcs.	24 pcs.	48 pcs.
Large Tray Filler	21 pcs.	16 pcs.	33 pcs.

**Note: Tray filler is built into unit and is not a separate piece.**

## 61" Pop-Up A-Frame Merchandiser

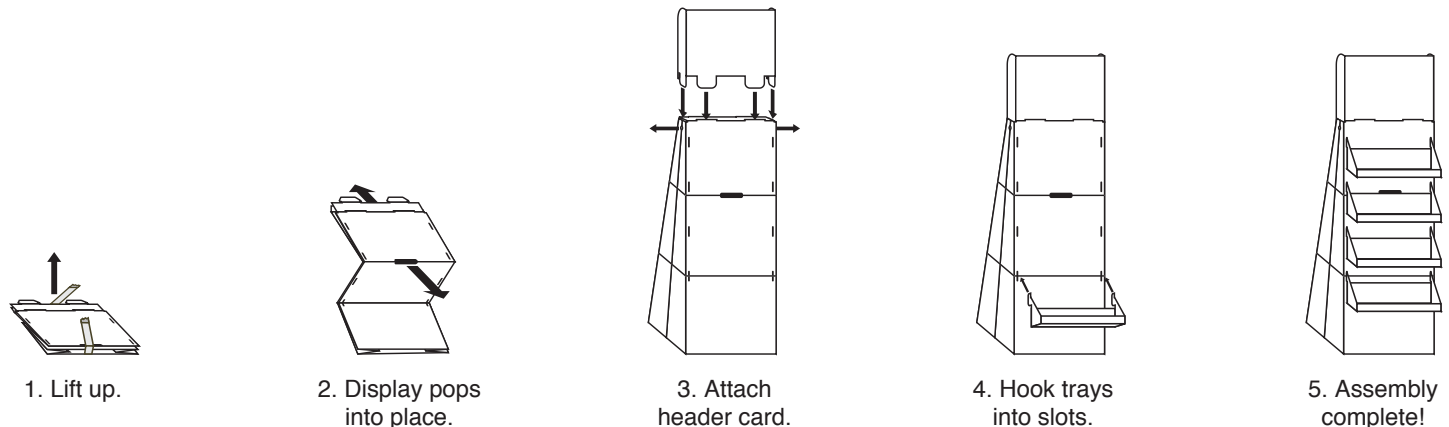
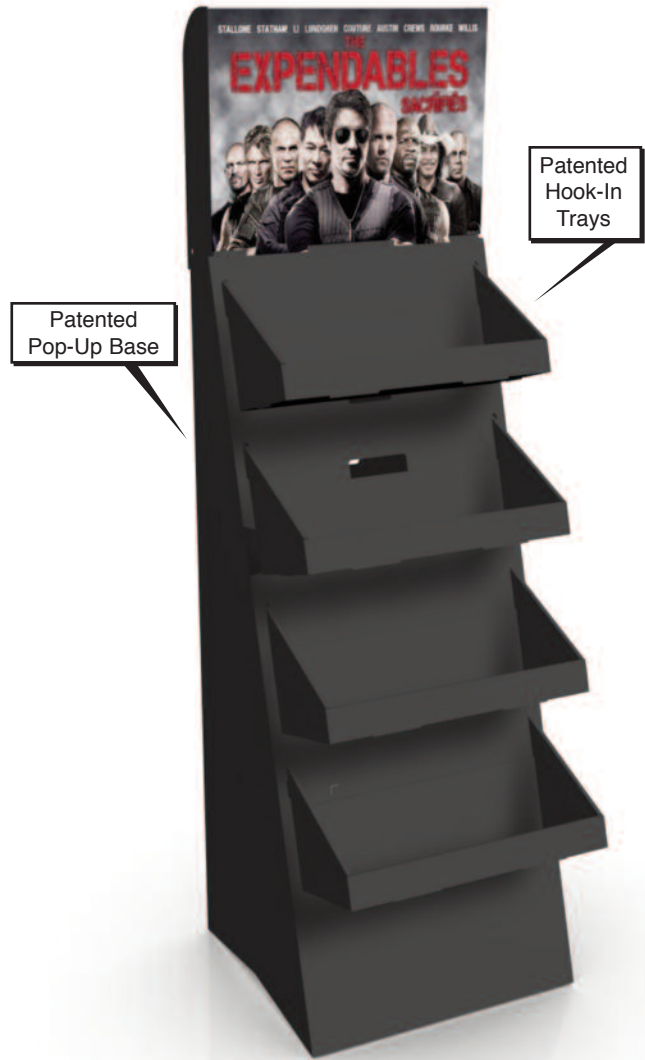

## Additional Pop-Up A-Frame Designs



## Pop-Up 1/4 - 1/2 Pallet Program

*Poptech has taken its generic pop-up A-Frame display, with all of its benefits and created a unique pallet program. The difference, these pallets can be stacked! Drastically reducing shipping costs when compared to conventional pallet programs.*

Quarter Pallet

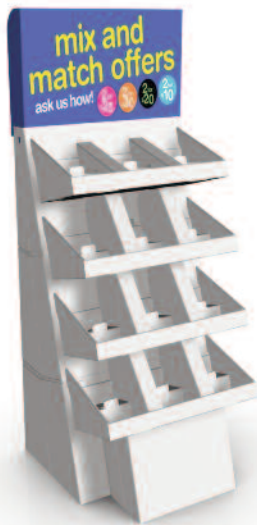

Half Pallet (A)



Half Pallet (B)

Full Pallet



Quarter Pallet

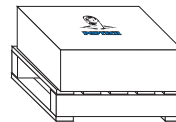

Half Pallet

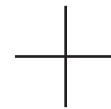
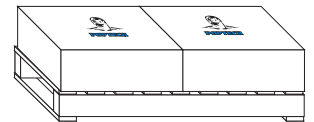

Full Pallet

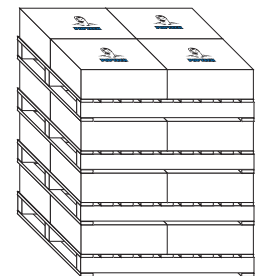
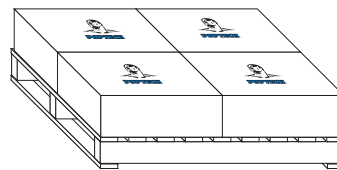

Take notice... These are the Cadillacs of our display line-up! Talk about getting the consumer to take notice, with an average 20 second set-up, this display is fully assembled, including the prepacked trays! And, if that wasn't impressive enough, this complex, yet simplified unit, comes with an industry first... Guaranteed Set-up!

**Client:** E1

**Specifications:**

- Patented Pop-Up Easel
- Patented Easy Lug-In Trays
- Patented Automatic Stabilizer

**Options:**

- Various shapes and sizes
- Multiple tray and / or peg configurations
- Lights and sound
- Existing in house dies

**72" Pop-Up Merchandiser**



Patented Pop-Up Easel



Patented Hook-In Trays

Patented Pop-Up Stabilizer

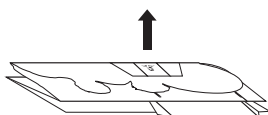

1. Lift up.

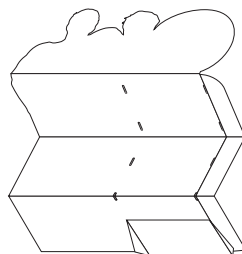

2. Display pops into place.

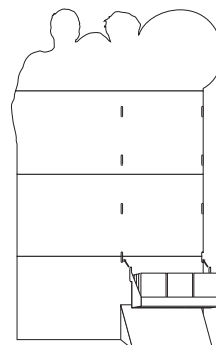

3. Starting at the bottom, hook trays into holes on display.

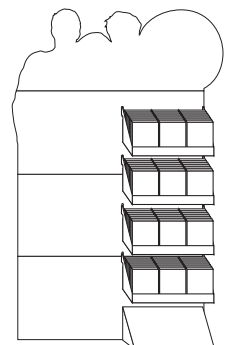

4. Assembly complete!



Take notice... Yet again! As with our pop-up merchandisers, this display delivers. It's like the client's getting two displays in one, a standee and a merchandiser.

**Client:** Bob Dale Gloves

**Specifications:**

Patented Pop-Up Easel  
Patented Automatic Stabilizer  
Pegs

**Options:**

Various shapes & sizes  
Multiple tray and / or peg configurations  
Lug-ons for 3D effects  
Existing in house dies

**72" Pop-Up 2-in-1  
Character Merchandiser**

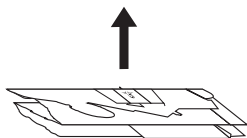

1. Lift up.

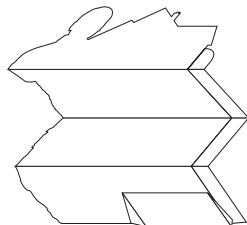

2. Display pops into place.

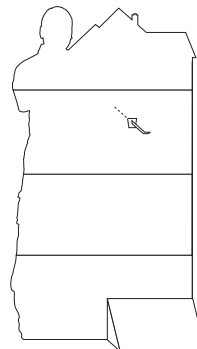

3. Hook pegs into holes on display..

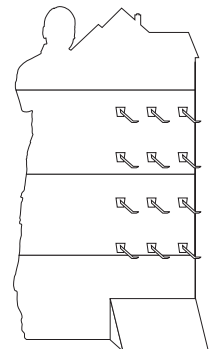

4. Assembly complete!

As with our Character Merchandiser, this unit is assembled complete in under 20 seconds flat! The 'Mini me' as it is affectionately known, was designed to handle a lighter line-up of product and save the client money by eliminating the need for a Stabilizer. Reduced pack out size, huge savings on shipping and Poptech's guaranteed set-up... need we say more?

**Client:** Heinz

**Specifications:**

Patented Pop-Up Easel  
Easy Lug-In Trays

**Options:**

Multiple sizes in tray or peg configurations  
With or without stabilizer  
Existing in house dies

**62" No Stabilizer  
Pop-Up Merchandiser**



Patented Pop-Up Easel



Patented Hook-In Trays

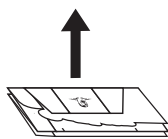

1. Lift up.

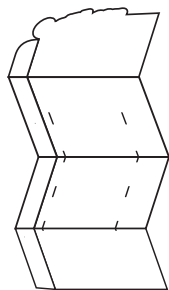

2. Display pops into place.

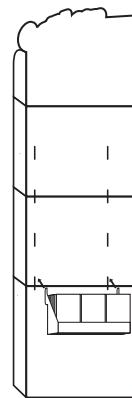

3. Lock shelf tabs into holes.  
Load display from bottom to top.

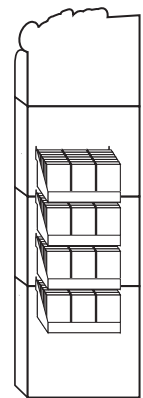

4. Assembly complete!

## Additional Pop-Up Merchandisers



## Customized Special Projects



3 Step Display



72" Pop-Up Standee With Full Size Lug-On Counter Top



4 Sided Multi Angle Floor Display



Counter Unit With Motion



Stacked Cube Floor Display



Multi-Dimensional Floor Display

# Poptech's Stock Dies & Patented Designs:

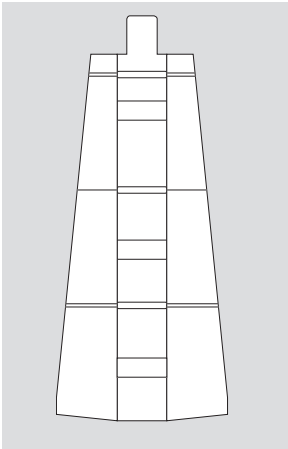

*Pop-Up Easels  
Various Sizes*

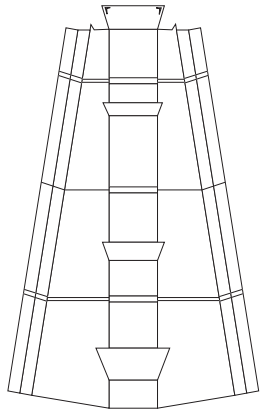

*Manual Tri-Fold  
Easel*

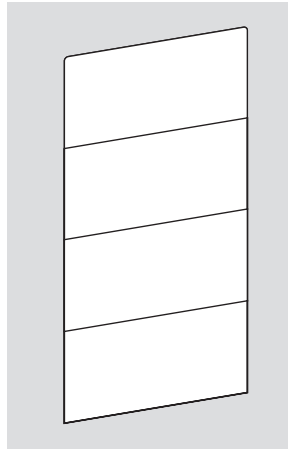

*Pop-Up Rectangle  
Standees*

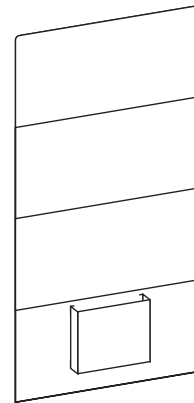

*Pop-Up 24"  
Brochure Holders*

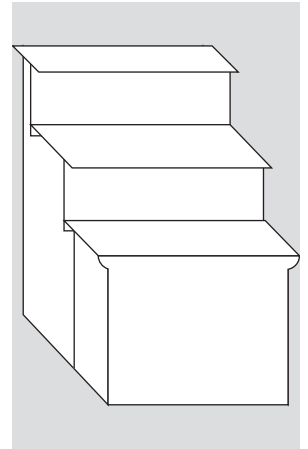

*1 Piece 3 Step*

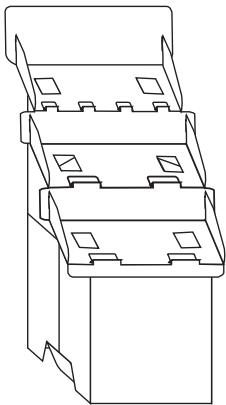

*Confection  
3 Step*

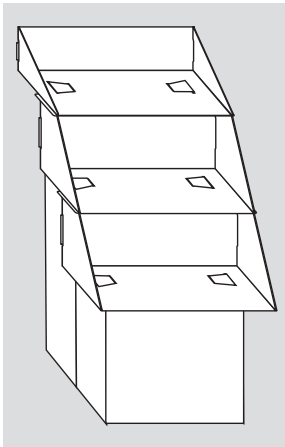

*Heavy Duty  
3 Step*

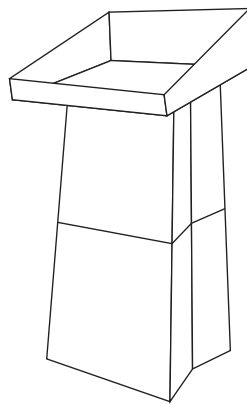

*Pop-Up  
Base & Tray*

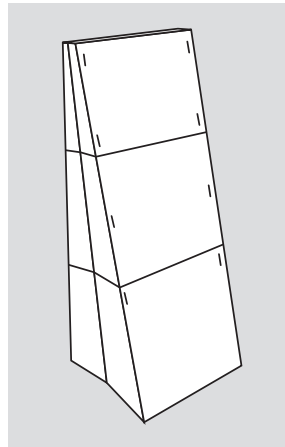

*Pop-Up A-Frames  
Various Sizes*

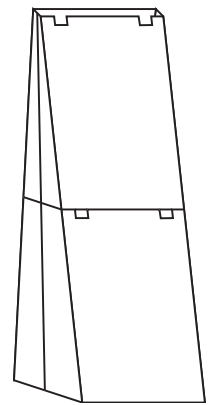

*Pop-Up Tiltback*

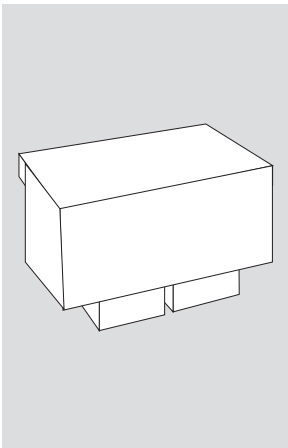

*Pop-Up  
Demo Table*

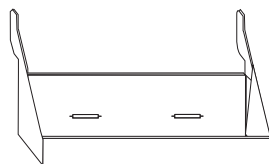

*Hook-In Trays  
Various Sizes*

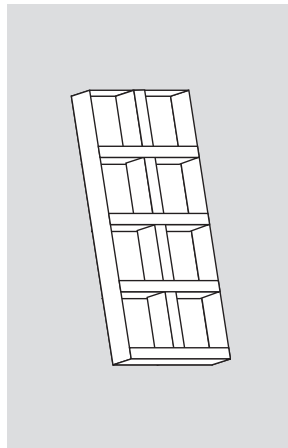

*Adjustable  
Sidekick Trays*

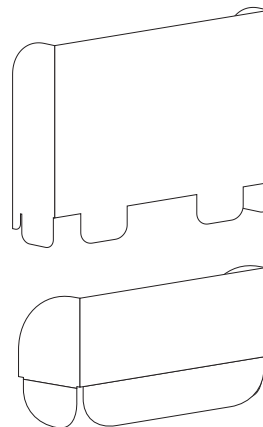

*A-Frame &  
Sidekick Headers*

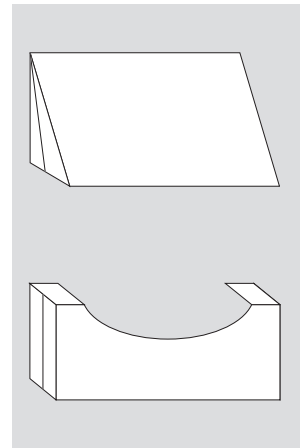

*Pop-Up Stabilizers  
& Tire Holder*

## **Clients who have utilized the Poptech Advantage:**

*Alliance Atlantis Films  
Armadale Vodka  
ATI Technologies  
BBDO  
Bell Mobility  
Best Western  
Brandworks  
Canadian Tire  
Coca Cola Bottling Co.  
Columbia Sportswear  
Draft  
Effem Foods (M&M's)  
Firestone Tires  
Fuji Film  
Ganz  
GJP Advertising  
HJ Heinz  
HSBC  
Integer Group  
Irwin Tools  
Kelloggs  
KFC  
Michelin Tire Co.  
Motorola  
NAPA Auto Parts  
Nascar  
Nestle  
Nintendo*

*OgilvyOne Worldwide  
Ontario Lotto Corporation  
Pepsi  
Proximity Group  
Reebok  
Robin Hood Foods  
Royal Bank  
Rubbermaid  
Sara Lee / Hillshire Farms  
Sealy  
Segal Communications  
Sharpe Blackmore  
Sirius  
Sony Electronics  
Sony Music  
The Meyocks Group  
The Production Kitchen  
Toyo Tire Co.  
Universal Studios  
Vincor Wines International  
Virgin Mobile  
Wal-Mart  
Walt Disney  
Warner Bros.  
Warner Music  
Wrigley's  
XBOX  
XM Radio*

## ***In closing...***

### ***Benefits to utilizing Poptech's technology***

- ***Quick time assembly -  Display Assembly Time Significantly decreasing time of in store assembly... Because time is money!***
- ***Smaller pack out sizes - Significantly decreasing warehousing and shipping costs. Put your budget where it matters most... The display!***
- ***Guaranteed Display Set-up - An industry first! Client gets exactly what they're paying for, significantly increasing the volume of product that actually hits the floor!***

***All at competitive pricing.***

***For more concepts & ideas visit our portfolio link @ [poptech.ca](http://poptech.ca)  
or call 1-800-813-6665***



**poptech**  
point of purchase technology

Let us show you first hand how our point of difference can make all the difference in the world.

poptech  
point of purchase technology